



# PROJECT CONCEPT NOTE

CARBON OFFSET UNIT (CoU) PROJECT

**Title:** 0.6 MW Small Scale Wind Power Project by M/s Mangalya Ceramics

Version 2.0

Date 21/09/2022

First CoU Issuance Period: 09 Years

Date: 01/01/2013 to 31/12/2021



Project Concept Note (PCN)  
CARBON OFFSET UNIT (CoU) PROJECT

**BASIC INFORMATION**

Title of the project activity	0.6 MW Small Scale Wind Power Project by M/s Mangalya Ceramics
Scale of the project activity	Small Scale
Completion date of the PCN	21/09/2022
Project participants	Creduce Technologies Private Limited (Representator) M/s Mangalya Ceramics (Developer)
Host Party	India
Applied methodologies and standardized baselines	Applied Baseline Methodology: AMS-I. D: "Grid connected renewable electricity generation", version 18  Standardized Methodology: Not Applicable.
Sectoral scopes	01 Energy industries (Renewable/Non-Renewable Sources)
Estimated amount of total GHG emission reductions	To be estimated during verification [An ex-ante estimate is 946 CoUs per year]

## **SECTION A. Description of project activity**

### **A.1. Purpose and general description of Carbon offset Unit (CoU) project activity >>**

The proposed project titled under UCR is “0.6 MW Small Scale Wind Power Project by M/s Mangalya Ceramics”, which is a Wind Power project located in Porbandar district in the state of Gujarat (India). The project is an operational activity with continuous reduction of GHG, currently being applied under “Universal Carbon Registry” (UCR).

#### **Purpose of the project activity:**

The project activity is a renewable power generation activity which incorporates installation and operation of single Wind Turbine Generator (WTG) having capacity of 0.6 MW manufactured and supplied by Suzlon Energy Ltd in district Porbandar of the state of Gujarat in India. This project has been promoted by M/s Mangalya Ceramics

The WTG under the project activity was commissioned on 29/03/2008 by Gujarat Energy Development Agency (GEDA), Government of Gujarat, India.

As per the ex-ante estimate, the project will generate approximately 1,051 MWh of electricity per annum. The net generated electricity from the project activity is being sold through Northern, Eastern, Western, and North-Eastern (NEWNE) grid as Power Purchase Agreement (PPA) signed between Gujarat Urja Vikas Nigam Limited (GUVNL) and PP (Project Proponent). The project activity would be displacing equivalent quantum of grid electricity resulting in emission reduction of 946 tCO<sub>2</sub> per annum. The project activity has been helping in greenhouse gas (GHG) emission reduction by using renewable resources (wind energy) for generating power which otherwise would have been generated using grid mix power plants, which is dominated by fossil fuel based thermal power plants.

The estimated annual average and the total CO<sub>2</sub>e emission reduction by the project activity is expected to be 946 tCO<sub>2</sub>e, whereas actual emission reduction achieved during the first CoU period shall be submitted as a part of first monitoring and verification.

Since the project activity generates electricity through wind energy, a clean renewable energy source it will not cause any negative impact on the environment and thereby contributes to climate change mitigation efforts.

#### **Project’s Contribution to Sustainable Development**

This project is a greenfield activity where grid power is the baseline. Indian grid system has been predominantly dependent on power from fossil fuel powered plants. The renewable power generation is gradually contributing to the share of clean & green power in the grid; however, grid emission factor is still on higher side which defines grid as distinct baseline.

The Government of India has stipulated following indicators for sustainable development in the interim approval guidelines for such projects which are contributing to GHG mitigations. The Ministry of Environment, Forests & Climate Change, has stipulated economic, social, environment and technological well-being as the four indicators of sustainable development. It has been envisaged that the project shall contribute to sustainable development using the following ways:

**Social well-being:** The project would help in generating direct and indirect employment benefits accruing out of ancillary units for manufacturing towers for erection of the Wind Turbine Generator (WTG) and for maintenance during operation of the project activity. It will lead to development of infrastructure around the project area in terms of improved road network etc. and will also directly contribute to the development of renewable infrastructure in the region.

**Economic well-being:** The project is a clean technology investment decided based on carbon revenue support, which signifies flows of clean energy investments into the host country. The project activity requires temporary and permanent, skilled and semi-skilled manpower at the project location; this will create additional employment opportunities in the region. The generated electricity will be displacing equivalent amount of electricity which otherwise would have been generated by fossil fuel sources, thereby reducing grid emission. In addition, improvement in infrastructure will provide new opportunities for industries and economic activities to be setup in the area. Apart from getting better employment opportunities, the local people will get better prices for their land, thereby resulting in overall economic development.

**Technological well-being:** The project activity employs state of art technology WTGs which has high power generation potential with optimised utilization of land. The successful operation of project activity would lead to promotion of this technology and would further push R&D efforts by technology providers to develop more efficient and better machinery in future. Hence, the project leads to technological well-being.

**Environmental well-being:** The project activity will generate power using zero emissions wind-based power generation facility which helps to reduce GHG emissions and specific pollutants like SO<sub>x</sub>, NO<sub>x</sub>, and SPM associated with the conventional thermal power generation facilities. The project utilizes wind energy for generating electricity which is a clean source of energy. The project activity will not generate any air pollution, water pollution or solid waste to the environment which otherwise would have been generated through fossil fuels. Thus, the project causes no negative impact on the surrounding environment contributing to environmental well-being.

#### **With regards to ESG credentials:**

At present specific ESG credentials have not been evaluated, however, the project essentially contributes to various indicators which can be considered under ESG credentials. Some of the examples are as follows:

#### **Under Environment:**

Environmental criteria may include a company's energy use, waste, pollution, natural resource conservation, and treatment of animals etc. For the project proponent, energy use pattern is now based on renewable energy due to the project and it also contributes to GHG emission reduction and conservation of depleting energy sources associated with the project baseline. Also, the criteria can be further evaluated on the basis of any environmental risks which the company might face and how those risks are being managed by the company. Here, as the power generation will be based on wind power, the risk of environmental concerns associated with non-renewable power generation and risk related to increasing cost of power etc. are now mitigated. Hence, project contributes to ESG credentials.

### **Under Social:**

Social criteria reflect on the company's business relationships, qualitative employment, working conditions with regard to its employees' health and safety, interests of other stakeholders' etc. With respect to this project, the Project Proponent has robust policies in place to ensure equitable employment, health & safety measures, local jobs creation etc. Also, the organizational CSR activities directly support local stakeholders to ensure social sustainability. Thus, the project contributes to ESG credentials.

### **Under Governance:**

Governance criteria relates to overall operational practices and accounting procedure of the organization. With respect to this project, the Project Proponent practices a good governance practice with transparency, accountability and adherence to local and national rules & regulations etc. This can be further referred from the company's annual report. The electricity generated from the project can be accurately monitored, recorded and further verified under the existing management practice of the company. Thus, the project and the proponent ensure good credentials under ESG.

## **A.2 Do no harm or Impact test of the project activity>>**

There was no harm identified from the project and hence no mitigations measures are applicable.

**Rational:** as per 'Central Pollution Control Board (Ministry of Environment & Forests, Govt. of India)', final document on revised classification of Industrial Sectors under Red, Orange, Green and White Categories (07/03/2016), it has been declared that wind project activity falls under the "White category". White Category projects/industries do not require any Environmental Clearance such as 'Consent to Operate' from PCB as such project does not lead to any negative environmental impacts. Additionally, as per Indian Regulation, Environmental and Social Impact Assessment is not required for Wind Projects.

Additionally, there are social, environmental, economic and technological benefits which contribute to sustainable development. The key details have been discussed in the previous section.

## **A.3. Location of project activity >>**

The project location is situated at Porbandar district in the state of Gujarat. The nearest airport is in Jamnagar. The project site is well connected by district and village roads to the nearest town. The geographic co-ordinates of the project locations are 21°41'24.8"N and 69°32'02.2"E.

The representative location map is included below:

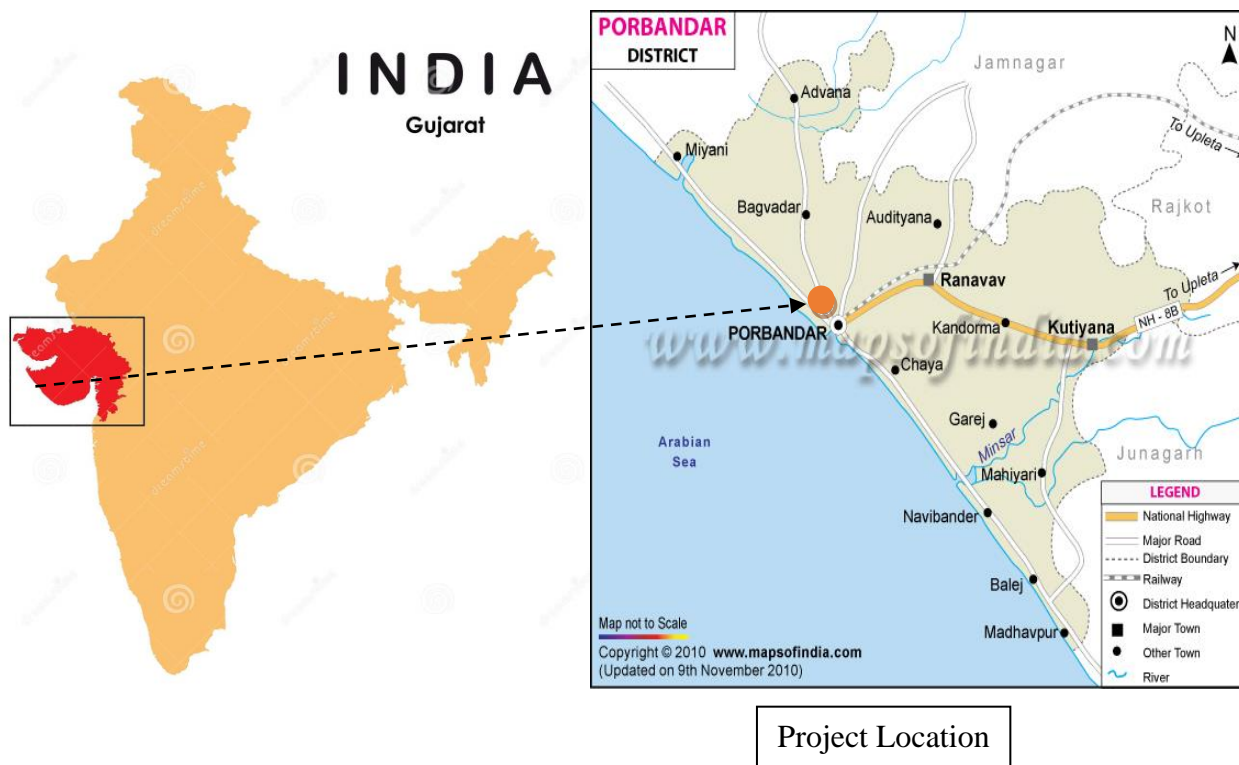

Project Location

(Courtesy: google images, www.mapofindia.com)

**A.4. Technologies/measures >>**

The proposed project activity is installation and operation of a Wind Turbine Generator (WTG) manufactured and supplied by Suzlon Energy Ltd. with an installed capacity of 0.6 MW in the state of Gujarat state of India.

Technical details for WTG Machine manufactured by Suzlon Energy Ltd. are as follows:

Product No.		S52_600kW_50 Hz
Main Data	Turbine type	Horizontal axis Wind Turbine
	Rated Power	600 kw
	Cut in Wind Speed	3.5 m/s
	Rated Wind Speed	12 m/s
	Cut off Wind Speed	25 m/s
	Hub Height	75 m
	Rotational Speed	24.19 rpm (fix speed machine, max over speed 28.29 rpm)
	Rotor Diameter	52 m
Main Frame	Swept Area	2,124 m <sup>2</sup>
	Frame type	Box frame
	Material	Cast Iron as per EN-GJS-400-18-LT and DIN EN 1563: 2003
Rotor	Corrosion Protection	Corrosion Proof painting
	No of Blades	3
	Tip Speed (at rated Power)	66m/sec

	Rotor axis tilt angle	5° w.r.t horizontal
	Power Regulation	Active pitch regulated
	Rotor Diameter	52 m
	Rotor orientation	Upwind/Horizontal axis
Generator	Frequency	50 Hz
	Type	Induction generator with slip rings
	Rotation Speed	1500 rpm
	Insulation	Class “H”
Rotor Blades	Rotor Blade type	AE 25 (with Vortex)
	Blade Length	25 m
	Material	GRP
	Type of rotor air brake	Pitch / Full blade
	Blade profiles	TU delft family
Pitch System	Pitch Type	Electrical
	Drive	Consists of one electric motor with gearbox & electrically operated brake for each blade
	Backup system	1 battery set per blade
	Pitch angle full range	-5° to +90°
	Pitch Speed (angular)	0.1 -10°/sec
Hub	Hub Type	Spherical hub
	Material	Cast iron as per EN-GJS-400-18U-LT and DIN EN 1563 :2003
	Corrosion Protection	Corrosion Proof Painting
Main Bearing	Bearing Type	Spherical roller bearing
	Quantity	1
Main bearing House	Bearing housing mounting	Foot cum flanged
	Quantity	1
Gear Box	Type of Gear Box	Integrated 1 planetary stage / 2 helical stages
	Material for gear Box housing	Cast iron – GGG 40.3
	Rotor	1:63.6
	Power	660 kW
	Manufacturer	Winergy
Oil Pump	Type of cooling	Forced oil cooling lubrication system
	Oil Pump motor voltage	3 phase – 690 V AC
	Oil Pump motor rating	4 kW
	Oil Pump Flow Rate	54 lit/min
Coupling	Coupling Type	Aprex Coupling, Constant speed
Generation System	Generator type	Induction generator (asynchronous), air cooled
	Rated Power	600 kW
	Rated Voltage	690 V AC (phase to phase)
	Frequency	50 HZ
	Number of poles	4
	Synchronous speed	1500 rpm
	Speed at rated power	1539 rpm

	Full Load power factor	0.89 approx. (uncompensated)
	Full load current	560 A
	Star winding connection	Delta
	Rotor	Squirrel cage
	Enclosure (Generator)	IP 56
	Insulation Glass	Class H
Yaw system – Bearing	Yaw Bearing Type	Polyamide Slide Bearing
Yaw System – yaw gear and Motors	Yaw Motor & gear type	Active electric yaw drive having electric motor with brake, gearbox and pinion
	Number of Units	2
	Yaw Speed	23.6°/ min
	Voltage	3 phase – 690 V AC
Tower	Tower Type	Lattice tower with bolted steel structure.
	Lattice Tower material	High tensile steel – S355JR as per DIN EN 10025 alternatively Grade 50B as per BS 4360
	Lattice tower Height	73.0 m
	Corrosion Protection	Hot dip galvanized, coating thickness 120 microns (Minimum)
	Access method	Ladder with safety harness
	Top dimensions	2.149 m * 2.149 m
	Foot Print Area	11.414 * 11.414 M
Wind Turbine main panel/ CPU panel	Capacitor Bank Voltage	3 Phase – 690 V AC
	Frequency	50 HZ
	Cut – in System	Soft- Starters using thyristors
Operational parameters	Wind Speed- Start	4 m/sec
	Wind Speed – stop	25 m/sec
	Re-start point, after high wind stop	23 m/sec
Electric Grid Connection	Voltage fluctuation	± 15%
	Frequency variations	-5 % to +4%
	Maximum asymmetric current	10 % of nominal current
	Maximum asymmetric voltage for 60 sec	2 %
	Maximum short circuit current	15kA at 690 V AC (phase to phase)
Mechanical brake (For maintenance purposes only)	Brake Type	Electro- mechanical disc brake + mechanical rotor lock
	Brake Disc	Steel disc, mounted on high-speed shaft
	Brake Caliper	1

Apart from the above technical specification of WTGs, the connectivity of all the WTGs is to a central Monitoring Station (CMS) through high-speed WLAN modem or fibre optic cable which helps in providing real time status of the turbine at CMS with easy GUI (Graphical User Interface)



and ability to monitor the functioning of the turbine from CMS.

A Supervisory Control & Data Acquisition System (SCADA) provides a graphical representation of data providing ease to understand the behaviour of WTG, long time data storage facility, access to daily generation report and power curve related information & helps to analyze the problem with graphical tools offline as well as online. The other specifications include a safety system with instrumentation for tracking individual functions of the wind turbine generator. The life time of the WTG is 20 years as per manufacturer specifications.

In the absence of the project activity the equivalent amount of electricity imported from NEWNE grid would have been generated from the NEWNE grid, which is predominantly based on fossil fuels<sup>1</sup>, hence baseline scenario of the project activity is the grid-based electricity system, which is also the pre-project scenario.

#### A.5. Parties and project participants >>

Party (Host)	Participants
India	<p><b>Creduce Technologies Private Limited (Representator)</b></p> <p>Contact person: Shailendra Singh Rao Mobile: +91 9016850742, 9601378723 Address: 2-O-13,14 Housing Board Colony, Banswara, Rajasthan - 327001, India</p> <p><b>M/s Mangalya Ceramics (Developer)</b> Address: Station Road, P.O Kanjari – 387325, Via Anand, Gujarat, India</p>

#### A.6. Baseline Emissions>>

The baseline scenario identified at the PCN stage of the project activity is:

- Grid

In the absence of the project activity, the equivalent amount of electricity would have been imported from the regional grid (which is connected to the unified Indian Grid system (NEWNE Grid)), which is carbon intensive due to predominantly sourced from fossil fuel-based power plants. Hence, baseline scenario of the project activity is the grid-based electricity system, which is also the pre-project scenario.

Schematic diagram showing the baseline scenario:

---

<sup>1</sup> [http://www.cea.nic.in/executive\\_summary.html](http://www.cea.nic.in/executive_summary.html)

**Baseline Scenario:**

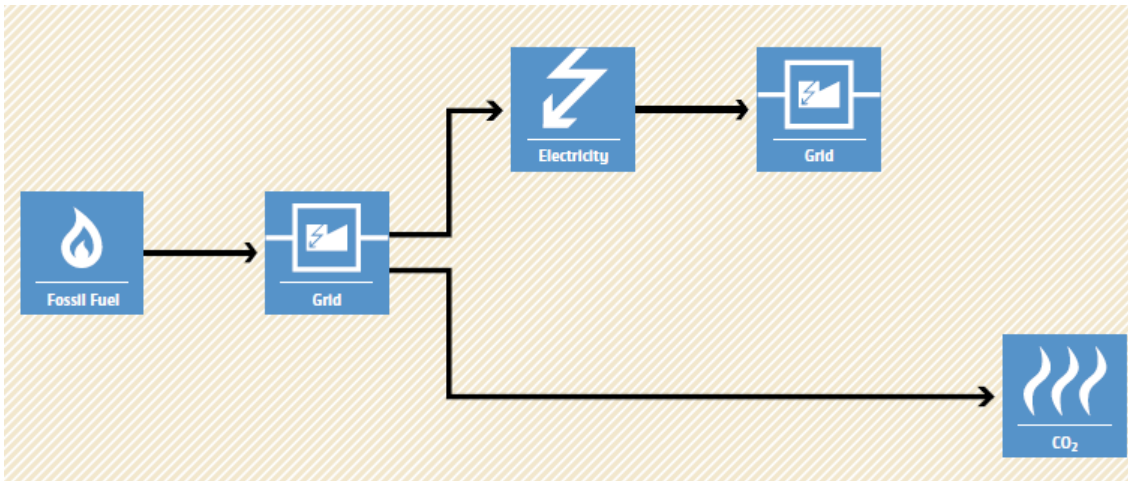

**Project Scenario:**

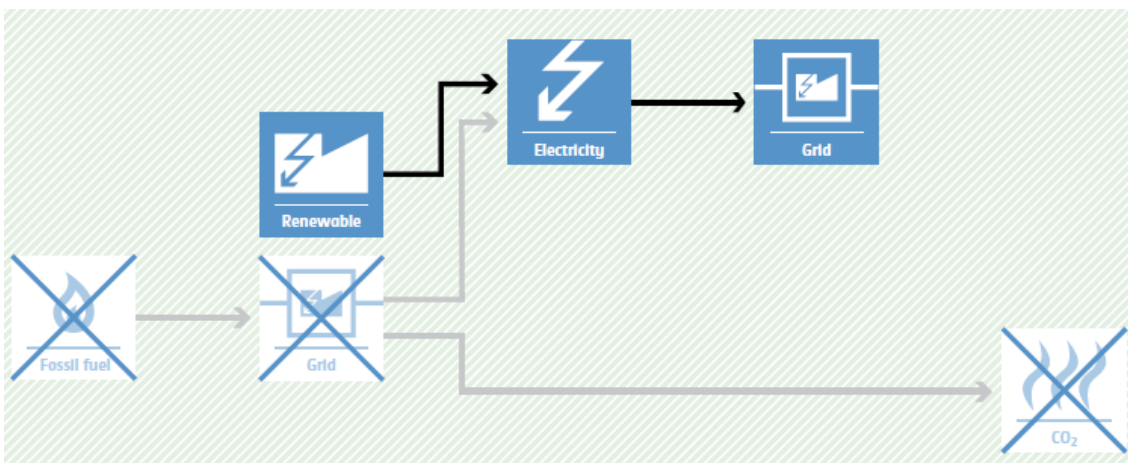

**A.7. Debundling>>**

This project activity is not a debundled component of a larger project activity.

## SECTION B. Application of methodologies and standardized baselines

### B.1. References to methodologies and standardized baselines >>

#### SECTORAL SCOPE:

01, Energy industries (Renewable/Non-renewable sources)

#### TYPE:

I - Renewable Energy Projects

#### CATEGORY:

AMS. I.D. (Title: “Grid connected renewable electricity generation”, version 18)

### B.2. Applicability of methodologies and standardized baselines >>

The project activity involves generation of grid connected electricity from the construction and operation of a new wind power-based power project. The project activity has installed capacity of 0.6 MW which will qualify for a small-scale project activity under Type-I of the Small Scale methodology. The project status is corresponding to the methodology AMS-I.D., version 18 and applicability of methodology is discussed below:

Applicability Criterion	Project Case
<p>1. This methodology comprises renewable energy generation units, such as photovoltaic, hydro, tidal/wave, wind, geothermal and renewable biomass:</p> <p>(a) Supplying electricity to a national or a regional grid; or</p> <p>(b) Supplying electricity to an identified consumer facility via national/regional grid through a contractual arrangement such as wheeling.</p>	<p>The project activity is a Renewable Energy Project i.e., wind power project which falls under applicability criteria option 1 (a) i.e., “Supplying electricity to a national or regional grid through Power purchase agreement.”</p> <p>Hence the project activity meets the given applicability criterion as well as satisfies the applicability illustration mentioned in Appendix of AMS-ID Table 1 – Scope of AMS-I.D. version 18.</p>
<p>2. This methodology is applicable to project activities that:</p> <p>(a) Install a Greenfield plant;</p> <p>(b) Involve a capacity addition in (an) existing plant(s);</p> <p>(c) Involve a retrofit of (an) existing plant(s);</p> <p>(d) Involve a rehabilitation of (an) existing plant(s)/unit(s); or</p> <p>(e) Involve a replacement of (an) existing plant(s).</p>	<p>The option (a) of applicability criteria 2 is applicable as project is a Greenfield plant /unit. Hence the project activity meets the given applicability criterion.</p>
<p>3. Hydro power plants with reservoirs that satisfy at least one of the following conditions are eligible to apply this methodology:</p> <p>(a) The project activity is implemented in</p>	<p>The project activity involves installation of Wind Turbine Generator (WTG); hence, this criterion is not applicable.</p>

<p>existing reservoir, with no change in the volume of the reservoir; or</p> <p>(b) The project activity is implemented in existing reservoir, where the volume of the reservoir(s) is increased and the power density as per definitions given in the project emissions section, is greater than 4 W/m<sup>2</sup>.</p> <p>(c) (c) The project activity results in new reservoirs and the power density of the power plant, as per definitions given in the project emissions section, is greater than 4 W/m<sup>2</sup></p>	
<p>4. If the new unit has both renewable and non-renewable components (e.g. a wind/diesel unit), the eligibility limit of 15 MW for a small-scale CDM project activity applies only to the renewable component. If the new unit co-fires fossil fuel, the capacity of the entire unit shall not exceed the limit of 15 MW.</p>	<p>The proposed project is 0.6 MW Wind power project, i.e., only component is renewable power project below 15MW, thus the criterion is not applicable to this project activity.</p>
<p>5. Combined heat and power (co-generation) systems are not eligible under this category</p>	<p>The project is wind power project and thus the criterion is not applicable to this project activity.</p>
<p>6. In the case of project activities that involve the capacity addition of renewable energy generation units at an existing renewable power generation facility, the added capacity of the units added by the project should be lower than 15 MW and should be physically distinct<sup>1</sup> from the existing units.</p>	<p>The proposed project is a greenfield 0.6 MW wind power project, i.e., only component is renewable power project below 15 MW, thus the criterion is not applicable to this project activity.</p>
<p>7. In the case of retrofit, rehabilitation or replacement, to qualify as a small-scale project, the total output of the retrofitted, rehabilitated or replacement power plant/unit shall not exceed the limit of 15 MW.</p>	<p>The proposed project is a greenfield 0.6 MW wind power project, i.e., only component is renewable power project below 15 MW, thus the criterion is not applicable to this project activity.</p>
<p>8. In the case of landfill gas, waste gas, wastewater treatment and agro-industries projects, recovered methane emissions are eligible under a relevant Type III category. If the recovered methane is used for electricity generation for supply to a grid, then the baseline for the electricity component shall be in accordance with procedure prescribed under this methodology. If the recovered methane is used for heat generation or cogeneration other applicable Type-I methodologies such as “AMS-I.C.: Thermal energy production with or without electricity” shall be explored.</p>	<p>The proposed project is a greenfield 0.6 MW wind power project; hence, this criterion is not applicable to this project activity.</p>
<p>9. In case biomass is sourced from dedicated plantations, the applicability criteria in the tool “Project emissions from cultivation of biomass” shall apply.</p>	<p>No biomass is involved, the project is only a wind power project and thus the criterion is not applicable to this project activity.</p>

### B.3. Applicability of double counting emission reductions >>

There is no double accounting of emission reductions in the project activity due to the following reasons:

- Project is uniquely identifiable based on its location coordinates,
- Project has dedicated commissioning certificate and connection point,
- Project is associated with energy meters which are dedicated to the consumption point for project developer

### B.4. Project boundary, sources and greenhouse gases (GHGs)>>

As per applicable methodology AMS-I.D. Version 18, “The spatial extent of the project boundary includes the project power plant and all power plants connected physically to the electricity system that the project power plant is connected to.”

Thus, the project boundary includes the Wind Turbine Generator (WTG) and the Indian grid system.

Source		Gas	Included?	Justification/Explanation
Baseline	Grid connected electricity generation	CO <sub>2</sub>	Yes	Main emission source
		CH <sub>4</sub>	No	Minor emission source
		N <sub>2</sub> O	No	Minor emission source
		Other	No	No other GHG emissions were emitted from the project
Project	Greenfield Wind Power Project Activity	CO <sub>2</sub>	No	No CO <sub>2</sub> emissions are emitted from the project
		CH <sub>4</sub>	No	Project activity does not emit CH <sub>4</sub>
		N <sub>2</sub> O	No	Project activity does not emit N <sub>2</sub> O
		Other	No	No other emissions are emitted from the project

### B.5. Establishment and description of baseline scenario >>

This section provides details of emission displacement rates/coefficients/factors established by the applicable methodology selected for the project.

As per the approved consolidated methodology AMS-I.D. Version 18, if the project activity is the installation of a new grid-connected renewable power plant/unit, the baseline scenario is the following:

**“The baseline scenario is that the electricity delivered to the grid by the project activity would have otherwise been generated by the operation of grid-connected power plants and by the addition of new generation sources into the grid”.**

The project activity involves setting up of a new wind power plant to harness the green power from wind energy. In the absence of the project activity, the equivalent amount of power would have been supplied by the Indian grid, which is fed mainly by fossil fuel fired plants. The power produced at grid from the other conventional sources which are predominantly fossil fuel based. Hence, the baseline for the project activity is the equivalent amount of power produced at the Indian grid.

A "grid emission factor" refers to a CO<sub>2</sub> emission factor (tCO<sub>2</sub>/MWh) which will be associated with each unit of electricity provided by an electricity system. The UCR recommends an emission factor of 0.9 tCO<sub>2</sub>/MWh for the 2013- 2021 years as a fairly conservative estimate for Indian projects not previously verified under any GHG program. Also, for the vintage 2021, the combined margin emission factor calculated from CEA database in India results into higher emission than the default value. Hence, the same emission factor has been considered to calculate the emission reduction under conservative approach.

### Net GHG Emission Reductions and Removals

Thus,  $ER_y = BE_y - PE_y - LE_y$

Where:

- $ER_y$  = Emission reductions in year y (tCO<sub>2</sub>/y)
- $BE_y$  = Baseline Emissions in year y (t CO<sub>2</sub>/y)
- $PE_y$  = Project emissions in year y (tCO<sub>2</sub>/y)
- $LE_y$  = Leakage emissions in year y (tCO<sub>2</sub>/y)

### Baseline Emissions

Baseline emissions include only CO<sub>2</sub> emissions from electricity generation in power plants that are displaced due to the project activity. The methodology assumes that all project electricity generation above baseline levels would have been generated by existing grid-connected power plants and the addition of new grid-connected power plants. The baseline emissions are to be calculated as follows:

$BE_y = EG_{PJ,y} \times EF_{grid,y}$

$BE_y$	=	Baseline emissions in year y (t CO <sub>2</sub> )
$EG_{PJ,y}$	=	Quantity of net electricity generation that is produced and fed into the grid as a result of the implementation of the CDM project activity in year y (MWh)
$EF_{grid,y}$	=	UCR recommended emission factor of 0.9 tCO <sub>2</sub> /MWh has been considered. (Reference: General Project Eligibility Criteria and Guidance, UCR Standard, page 4)

### Project Emissions

As per Paragraph 39 of AMS-I.D. version-18, only emission associated with the fossil fuel combustion, emission from operation of geo-thermal power plants due to release of non-condensable gases, emission from water reservoir of Hydro should be accounted for the project emission. Since the project activity is a wind power project, project emission for renewable energy plant is nil.

**Thus, PE = 0**

### Leakage

As per paragraph 42 of AMS-I.D. version-18, 'If the energy generating equipment is transferred from another activity, leakage is to be considered.' In the project activity, there is no transfer of energy generating equipment and therefore the leakage from the project activity is considered as zero.

**Hence, LE = 0**

The actual emission reduction achieved during the first CoU period shall be submitted as a part of first monitoring and verification. However, for the purpose of an ex-ante estimation, following calculation has been submitted:

Estimated annual baseline emission reductions (BEy)

= 1,051 MWh/year \*0.9 tCO2/MWh

= 946 tCO2/year (i.e., 946 CoUs/year)

#### **B.6. Prior History>>**

The project activity is a bundle of wind machines. Following are the key details under the prior history of the project:

- (a) The project was not applied under any other GHG mechanism. Hence project will not cause double accounting of carbon credits (i.e., COUs).

#### **B.7. Changes to start date of crediting period >>**

The start date of crediting period is changed to 01/01/2013 as per the new UCR project standard.

#### **B.8. Permanent changes from PCN monitoring plan, applied methodology or applied standardized baseline >>**

Not applicable.

#### **B.9. Monitoring period number and duration>>**

First Issuance Period: 09 Years

Date: 01/01/2013 to 31/12/2021 (inclusive of both dates).

## B.10. Monitoring plan>>

### Data and Parameters available at validation (ex-ante values):

Data / Parameter	UCR recommended emission factor
Data unit	tCO <sub>2</sub> /MWh
Description	A "grid emission factor" refers to a CO <sub>2</sub> emission factor (tCO <sub>2</sub> /MWh) which will be associated with each unit of electricity provided by an electricity system. The UCR recommends an emission factor of 0.9 tCO <sub>2</sub> /MWh for the 2013- 2021 years as a fairly conservative estimate for Indian projects not previously verified under any GHG program. Hence, the same emission factor has been considered to calculate the emission reduction under conservative approach.
Source of data	<a href="https://a23e347601d72166dcd6-16da518ed3035d35cf0439f1cdf449c9.ssl.cf2.rackcdn.com//Documents/UCRStandardAug2022updatedVer5_030822005728911983.pdf">https://a23e347601d72166dcd6-16da518ed3035d35cf0439f1cdf449c9.ssl.cf2.rackcdn.com//Documents/UCRStandardAug2022updatedVer5_030822005728911983.pdf</a>
Value applied	0.9
Measurement methods and procedures	-
Monitoring frequency	Ex-ante fixed parameter
Purpose of Data	For the calculation of Emission Factor of the grid
Additional Comment	The combined margin emission factor as per CEA database (current version 16, Year 2021) results into higher emission factor. Hence for 2021 vintage UCR default emission factor remains conservative.

### Data and Parameters to be monitored (ex-post monitoring values):

Data / Parameter	EG <sub>PJ, facility, y</sub>
Data unit	MWh
Description	Net electricity supplied to the NEWNE grid facility by the project activity
Source of data	Wind energy certificate issued by GETCO (Gujarat Energy Transmission Corporation Limited)
Measurement procedures (if any):	Data Type: Measured Monitoring equipment: Energy Meters are used for monitoring Archiving Policy: Electronic Calibration frequency: Once in 5 years (considered as per provision of CEA India).  The net electricity generated by the project activity will be calculated from net electricity supplied to grid from the share certificate issued by state utility (currently GETCO) on monthly basis for respective WTGs. The amount of energy supplied by the WTGs are continuously monitored and recorded once a month. The same can be cross-checked from the State utility website which is publicly available.
Measurement Frequency:	Monthly
Value applied:	1051 (Ex-ante estimate)



QA/QC procedures applied:	Continuous monitoring, hourly measurement monthly recording. Tri-vector (TVM)/ABT energy meters with accuracy class 0.2s
Purpose of data:	The Data/Parameter is required to calculate the baseline emission.
Any comment:	Data will be archived electronically for a period of 36 months beyond the end of crediting period.